

Part Reference: 390L40-EZCB1

REV.	DATE	DESCRIPTION
A	2014.11.25	

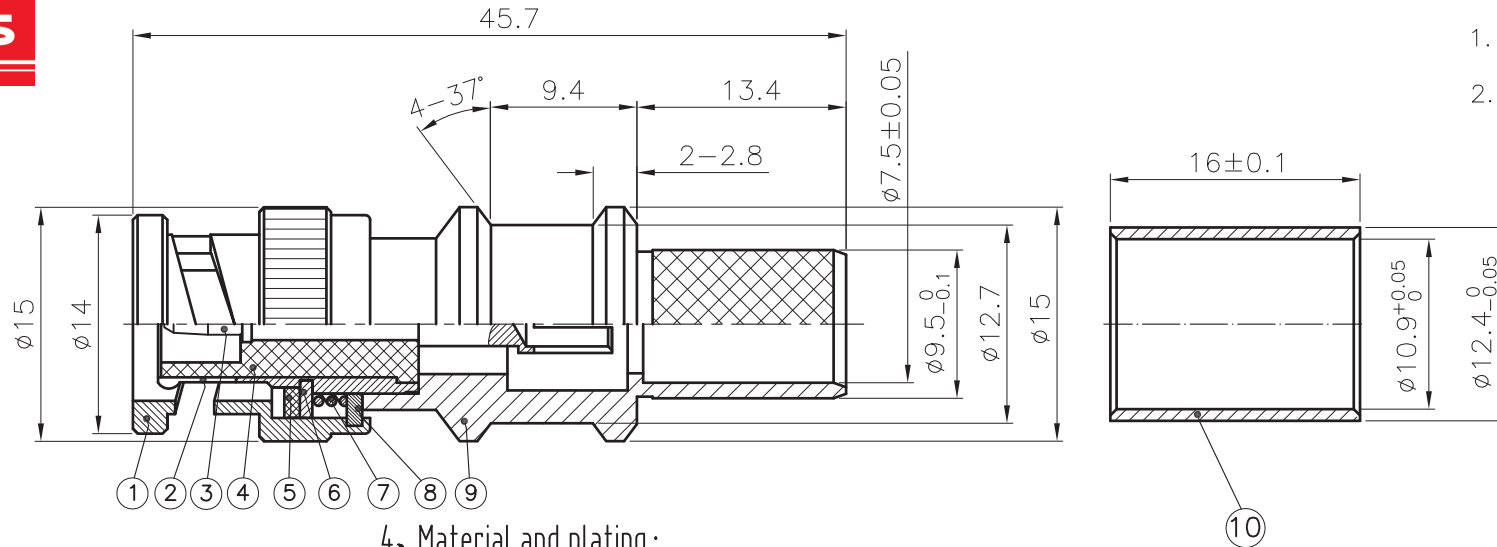

- 1. CRIMPED FERRULE
HEX. CRIMP SIZE 0.429"
- 2. CONTACT PIN SOLDERLESS

1. ELECTRICAL :

- 1.1. Nominal Impedance : 50Ω ;
- 1.2. Frequency range : 0~4GHz ;
- 1.3. VSWR : ≤1.35 ;
- 1.4. Contact Resistance :
Center Contact : ≤3 mΩ ;
Outer Contact : ≤2 mΩ ;
- 1.5. Dielectric Voltage : 500Vrms ;
- 1.6. Insulation Resistance : ≥5000MΩ ;
- 1.7. Insertion loss:According as the cable ;

2. Mechanical :

- 2.1. Interface Dimensions:IEC60169-22 ;
- 2.2. Durability : 500cycles min ;

3. Environmental :

- 3.1. Operating Temp. Range:-40℃~+80℃ ;

4. Material and plating :

- BODY : BRASS, NICKEL PLATING ;
- COUPLING NUT : BRASS, NICKEL PLATING ;
- OUTER CONTACT : BRASS, NICKEL PLATING ;
- CENTER CONTACT : BRONZE, GOLD PLATING ;
- INSULATOR : PTFE ;
- FERRULE : SOFT BRASS, NICKEL PLATING ;
- GASKET : SILICONE RUBBER

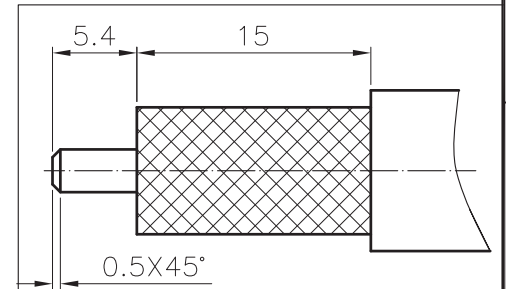

TITLE BNC MALE SOLDERLESS CONTACT PLUG FOR LMR400 CABLE	REV.	A	SCALE	4/1	PART NO.	
	PROJECTION				APPROVED	DATE
DRAWING NO.	UNLESS OTHERWISE SPECIFIED TOLERANCES TOLERANCES				CHECKED	DATE
	1. * ±0.2 4 T.I.R 0.1 2. ** ±0.1 5. SURFACE ROUGHNESS Ra1.6 3. ANGLE ±3° 6. EDGES CO.15 MAX.				DRAWN	DATE
* MAJOR DIMENSION						