

# Part Reference: 390L60-EZCN2

REV.	DATE	DESCRIPTION
A	2014.11.20	

- 1. CRIMPED FERRULE  
HEX. CRIMP SIZE 0.610"
- 2. CONTACT PIN SOLDERLESS

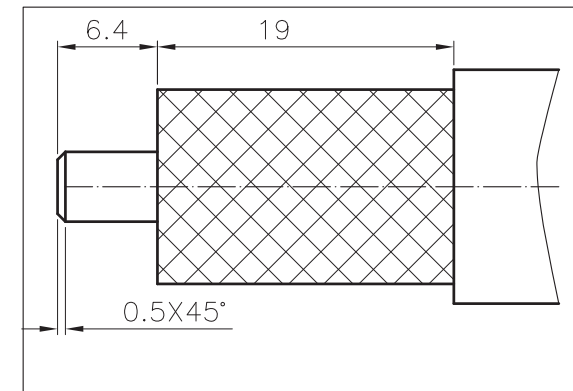
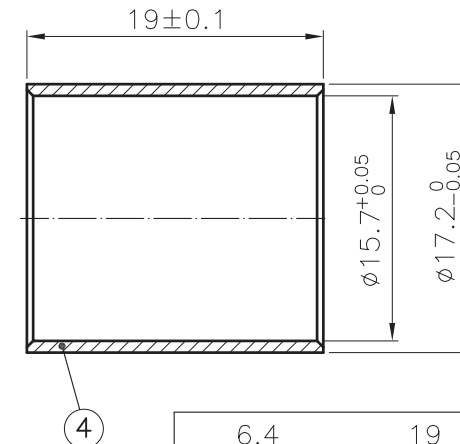
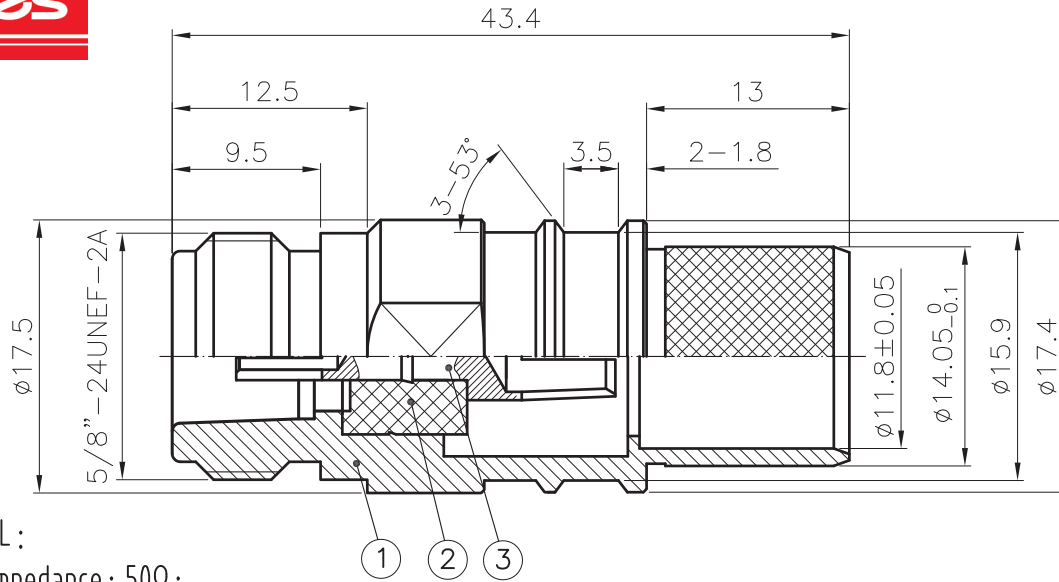

## 1. ELECTRICAL :

- 1.1. Nominal Impedance : 50Ω ;
- 1.2. Frequency range : 0~6GHz ;
- 1.3. VSWR : ≤1.3 ;
- 1.4. Contact Resistance :  
Center Contact : ≤0.8mΩ ;  
Outer Contact : ≤0.4mΩ ;
- 1.5. Dielectric Voltage : 2500Vrms ;
- 1.6. Insulation Resistance : ≥5000MΩ ;
- 1.7. Insertion loss:0.1dB(DC-3GHz) ;

## 4. Material and plating:

- BODY : BRASS , NICKEL PLATING ;
- CENTER CONTACT : BRONZE , GOLD PLATING ;
- INSULATOR : PTFE ;
- FERRULE : SOFT BRASS , NICKEL PLATING ;

## 2. Mechanical :

- 2.1. Interface Dimensions:IEC60169-16 ;
  - 2.2. Durability : 500cycles min ;
- ## 3. Environmental :
- 3.1. Operating Temp. Range:-40℃--+80℃ ;

TITLE FEMALE SOLDERLESS CONTACT PLUG FOR LMR600 CABLE	REV.	A	SCALE	2/1	PART NO.	
	PROJECTION				APPROVED	DATE
DRAWING NO.	UNLESS OTHERWISE SPECIFIED TOLERANCES				CHECKED	DATE
	1. * ±0.2		4 T.I.R 0.1		DRAWN	DATE
		2. ** ±0.1		5. SURFACE ROUGHNESS Ra1.6		
		3. ANGLE ±3°		6. EDGES CO.15 MAX.		
* MAJOR DIMENSION						